

LIQUID SOAP DISPENSER WP173 FOR MOUNTING IN CABINET



67(69) x 259(221) x 97(88) mm

500 ml or 950 ml soap bottle or 850 ml plug-in tank

- Liquid soap dispenser in robust, germ-reducing and easy-care stainless steel (AISI 316L).
- For mounting in cabinet on site.
- One-hand operated and non-drip soap pump.
- Designed for standard 500 ml or 950 ml disposable bottles of liquid soap or hand lotion. Refillable from the top.
- Also refillable with large container using the plug-in tank as an option.
- Wear parts can be replaced as modules.
- Mounting: With two screws through key holes and one optional anti-theft hole in the back wall.
- Delivery includes fixing material, self-adhesive information label „Soap“ and first fill with soap.
- Weight, including single package: 2.7 kg



Suggested text for specifications:

Liquid soap dispenser in stainless steel (AISI 316L) for mounting in cabinet. One-hand operated and non-drip soap pump. Designed for standard 500 ml or 950 ml disposable bottles of liquid soap or hand lotion. Refillable from the top. Delivery includes fixing material, self-adhesive information label „Soap“ and first fill with soap.

Dimensions: 67(69) x 259(221) x 97(88) mm

Article No. WP173

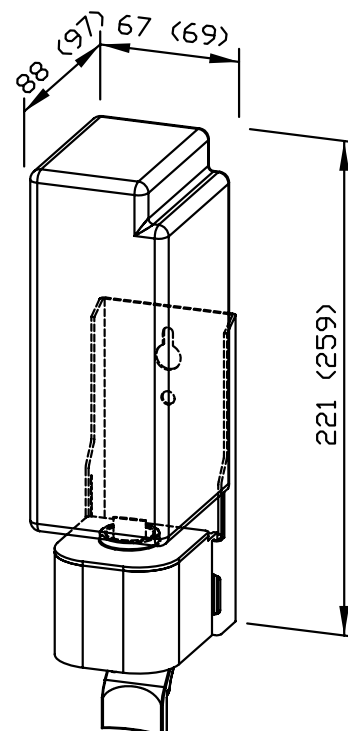

Options	ID No.
Plug-in tank 850 ml	937 201
Available surface	ID No.
satin finished	727 173

Ernst Wagner GmbH & Co. KG

Ernst-Abbe-Straße 21 · D-72770 Reutlingen · Tel.: +49712151539-0 · Fax: -20
info@wagner-ewar.de · www.wagner-ewar.de

WAGNER
EWAR