

SENSOR-DISINFECTANT DISPENSER WP173E-7 FOR MOUNTING IN CABINET



87 x 248 x 120 mm

950 ml tank

- Sensor disinfectant dispenser in robust, germ-reducing and easy-care stainless steel (AISI 316L).
- For mounting in cabinet on site.
- With EWAR® eModule touch-free operated disinfectant pump with 950 ml tank.
- Tank with large, lockable refill opening.
- Designed for standard disinfectants. Refillable from the top.
- eModule battery-powered with two 1.5 V Baby/LR14 batteries. Power supply available as an option.
- Wear parts can be replaced as modules.
- Mounting: With three screws through key holes in the back wall.
- Delivery includes fixing material, batteries and self-adhesive information label „disinfectant“.
- Weight, including single package: 1.1 kg



Suggested text for specifications:

Sensor disinfectant dispenser in stainless steel (AISI 316L) for mounting in cabinet. With touch-free operated disinfectant pump with 950 ml tank. Designed for standard disinfectants. Refillable from the top. Delivery includes fixing material, batteries and self-adhesive information label „Disinfectant“.

Dimensions: 87 x 248 x 120 mm

Article No. WP173e-7

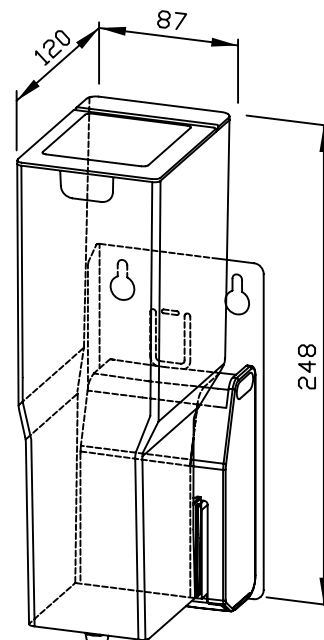

Options	ID No.
Power supply for eModule	923 060

Available surface	ID No.
satın finished	727 186

Ernst Wagner GmbH & Co. KG

Ernst-Abbe-Straße 21 · D-72770 Reutlingen · Tel.: +49712151539-0 · Fax: -20
info@wagner-ewar.de · www.wagner-ewar.de

WAGNER
EWAR