

SENSOR LIQUID SOAP DISPENSER WP174E FOR MOUNTING BEHIND FIXED MIRROR



86 x 207 x 148 mm

200 ml soap tank

- Sensor liquid soap dispenser in robust, germ-reducing and easy-care stainless steel (AISI 316L).
- For mounting behind fixed mirror on site.
- With EWAR® eModule touch-free operated and non-drip soap pump with 200 ml tank.
- Tank with large, lockable refill opening.
- Designed for standard liquid soaps or hand lotions. Accessible for refilling through spring stop pin and by removing from below.
- eModule battery-powered with two 1.5 V Baby/LR14 batteries. Power supply available as an option.
- Wear parts can be replaced as modules.
- Mounting: With two screws through key holes and one optional anti-theft hole in the back wall. Depth of substructure installation: min. 185 mm Height above vanity unit: min. 200 mm
- Delivery includes fixing material and self-adhesive information label „Soap“.
- Weight, including single package: 1.2 kg



Suggested text for specifications:

Sensor liquid soap dispenser in stainless steel (AISI 316L) for mounting behind fixed mirror. With touch-free operated and non-drip soap pump with 200 ml tank. Designed for standard liquid soaps or hand lotions. Accessible for refilling through spring stop pin and by removing from below. Delivery includes fixing material, batteries and self-adhesive information label „Soap“.

Dimensions: 86 x 207 x 148 mm

Article No. WP174e

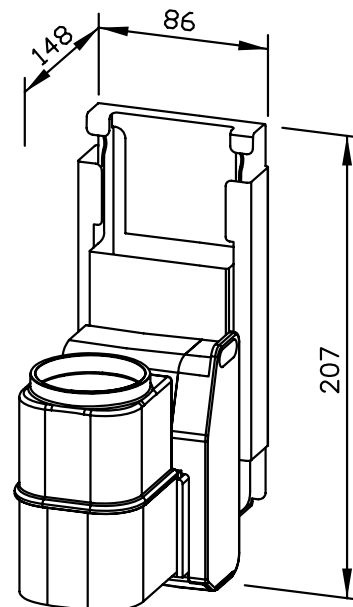

Options	ID No.
Power supply for eModule	923 060

Available surface	ID No.
satin finished	727 038

Ernst Wagner GmbH & Co. KG

Ernst-Abbe-Straße 21 · D-72770 Reutlingen · Tel.: +49712151539-0 · Fax: -20
info@wagner-ewar.de · www.wagner-ewar.de

WAGNER
EWAR